



Rumbleseat Review



www.wichitaas.com

WICHITA A'S MODEL A FORD CLUB

Volume 38 Issue 9

P.O. Box 25, Wichita, KS

September 2023

September 2023

S	M	T	W	TH	F	S
					1	2
3	4	5	6	7	8	9
10	11	12	13	14	15	16
17	18	19	20	21	22	23
24	25	26	27	28	29	30

October 2023

S	M	T	W	TH	F	S
1	2	3	4	5	6	7
8		10	11	12	13	14
15	16	17	18	19	20	21
22	23	24	25	26	27	28
29	30					

November 2023

S	M	T	W	TH	F	S
			1	2	3	4
5	6	7	8	9	10	11
12	13	14	15	16	17	18
19	20	21	22		24	25
26	27	28	29	30		

September is

Appreciation

Dinner 6:30 PM

CLUB TOURS & MEETING SCHEDULE

September 2023



25..... Club Meeting at Minisa Park 704 W. 13th6:30PM
 Annual Meeting& Appreciation Dinner.....

October 2023



6..... Newsletter Deadline ...sheorr@sbcglobal.net.....Sheila Orr
 8..... All Fords Day.....Jim Clark
 23..... Club Meeting at Minisa Park 704 W. 13th.....7:00PM
 27-28..... Men's Tour.....Steve White

November 2023



10..... Newsletter Deadline...sheorr@sbcglobal.net.....Sheila Orr
 27..... Club Meeting at Minisa Park 704 W 13th.....7:00PM

Don't forget to pay your membership dues!

WHAT'S INSIDE

Calendar	1
President & Secretary Notes	2-3
Announcements	4
Past Tour	5-8
Future Tours	9
Membership Renewal	10
National News	11
Tech Talk	12
Era Fashion	13
Swap Meet/ Nat'l Schedule	14

The Wichita A's meet on the 4th Monday of the month except December. We do not hold a meeting during the month of December. Other meeting changes will be published in the newsletter prior to the scheduled meeting. The meetings are held at Minisa Park, 704 W. 13th, Wichita, KS. Meeting time is 7:00 PM unless otherwise noted in the newsletter.

Wichita A’s Model A Club Meeting-August 28, 2023

CALL MEETING TO ORDER AND FLAG SALUTE – Vice President, **Frank Chenoweth**, called the meeting to order and led the group in reciting the Pledge of Allegiance.

THIS MONTH’S STORY – **Frank Chenoweth** shared a story of the evening.

SUNSHINE REPORT – **Bonita Graham** gave an update on President **James Sharp**’s health status.

MINUTES (July 24, 2023) – Motion was made and seconded to approve the minutes.

TREASURERS REPORT– **Claudia Ellerman** gave the treasurer’s report.

CORRESPONDENCE – A note was received from **Gil Adams**, thanking club members for all the cards that have been sent to him following his recent surgery. Gil is feeling much better.

WACCC- **Stuart McNeal** announced that the WACC has listed its fall car shows on Facebook.

PREVIOUS TOURS OR EVENTS –No recent tours to report.

FUTURE TOURS OR EVENTS – **Mike James** announced sign ups are being taken for the Sept. 9th Ellinwood Tunnel Tour with lunch at the Wolf Hotel. **Don Grabendike** is coordinating the Motorcycle Cannonball Tour is on Sept. 14th in Augusta, KS. All Fords Day on 10/1/23 is being planned by **Jim Clark**. The Men’s Tour is being planned by **Steve White**, from Great Bend, on October 27th and 28th. It will include a private air show and viewing of an antique car collection. It was announced that there is also a Big Papa’s Road Run Car Show sponsored by Danny Stang and Dave Moore on September 16, 2023 from 10am – 2pm at 12400 N. Hoover Road in Sedgwick, KS. The event is FREE.

OLD BUSINESS – none.

NEW BUSINESS – Club dues are due October 1st. The form to be completed and submitted with your dues will be in the August Newsletter. .

REFRESHMENTS – Refreshments were provided by **Carolyn Nungesser, Sheila Orr, Susan Stone**. At the September meeting a catered dinner will be provided, since we will have election of officers that night. Members are asked to bring a side or a dessert.

PROGRAM-A video, The New 40 Horses was shown.

ADJOURNMENT –**Frank Chenoweth** adjourned the meeting.

Minutes recorded by **Mike James**

Submitted by **Kathy James**, Secretary

Editors Notes

Hello Almost Fall! The last few days have given us a glimpse of what Fall might feel like! I am tired of the HOT summer, so ready for temperature change. Last weekend was a great tour of Ellinwood Tunnels. Very informative and interesting tour. Come join the group in the next adventure.

This week brings the Appreciation Dinner. Also our election of new officers. Please plan on attending,

Also, a reminder the annual dues are payable to membership chairman, **Linda Kibbe**, so don’t forget.

Enjoying the peaceful fall, before the hectic Holidays-Until next month

Sheila Orr, Editor



President's Message for September 2023

September is our Annual meeting where the club will elect officers for the coming year. The nominating committee has a slate of officers that will be presented to the membership for their consideration.

The September meeting will start at **6:30 PM** instead of the usual starting time of 7PM. This is to allow us time to eat and have the meeting. We will be having a meal in conjunction with the annual meeting the same as we did last year.

Here are the details of the September meeting. The following is being provided, courtesy of the club: 2 meats and 2 sides (green beans and baked beans). We are asking members to bring either an additional side or dessert to complete the meal.

It has been my pleasure to serve as your president for the past two years. I wish to thank all those who have worked hard to make our club a success. We have had many interesting tours and programs. Please plan on attending the annual meeting on September 25.

Your President,
James Sharp

NOMINATING COMMITTEE

The nominating committee has submitted a slate of officers for the 2024 year.

Frank Chenoweth-President
Rick Speck- Vice President
Kathy James- Secretary
Claudia Ellerman- Treasurer
Judi Sharp- Member at Large

At our meeting on Monday, September 25, 2023, we will be voting on new officers along with having our Appreciation Dinner. Please plan to attend.

CLUB DUES ARE DUE OCT 1!

Wichita A's Club dues are still just \$25 per family! They are due October 1 (and late December 15). There is a form in this newsletter and also on the Wichita A's website: wichitaas.com. You may pay at the meeting or mail your dues to the club address on the form.

Please Mark whether you would like your newsletter e-mailed and/or sent in the mail
IF NO updates – use the short version.



Announcements

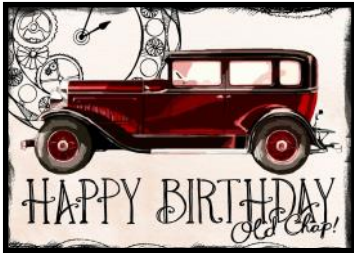

MAFCA Membership

MAFCA Membership Longevity
Steve & Jane McLaughlin 40 years
Richard & Linda Kibbe 30 years
Congrats to them!!

New Member

John Vsetecka
5830 Broadway Ave.
Great Bend, KS 67530-3124
J: 620-617-1553
'29 Tudor

- October Birthdays**
- 2 Dick Price
 - 2 Lynn Wilson
 - 3 Kathryn Halfman
 - 5 Jeremie Hildibrand
 - 8 Paulina Brashear
 - 15 Lance Brashear
 - 18 Richard Kibbe
 - 19 Dale Hellar
 - 19 Barb Phye
 - 21 Melissa Giordano
 - 22 Ron Cole
 - 24 David Beaver
 - 24 Steve McLaughlin
 - 26 Linda Kibbe
 - 27 Kim Giesen
 - 28 Dean Gier
 - 30 Wanda Steffens

For Sale



1931 Victoria



1931 4 door Slant Window

More pictures available on request from Sheila. Contact **Doris Jean Ludlow** at 316-721-9945 for more information.

MAF- FI BRICK COLLECTION

There was \$2.55 balance after brick purchase. We collected \$33.00 in the Headlight from the August meeting. Total is now \$35.55.



Denny Ellerman

Refreshments



Newsletter Deadline

Friday, October 6, 2023
Sheila Orr
sheorr@sbcglobal.net or
316-207-8878

September	October	November
Appreciation	Beverage Brenda Broadhead	Beverage Jeannie Speck
Dinner	Treat Glenda Sill Doris Jean Ludlow Donna Hileman	Treats Sheila Orr Greg Rau Claudia Ellerman

Ellinwood Tunnel tour 2023



Ellinwood, Kansas was founded in 1871 by German immigrants who used basements and tunnels in their home country for access to their various business establishments. The early settlers in Ellinwood adopted similar construction methods and built the main street business district with a series of basements and tunnels. The tunnels allowed for supplies to be brought into hotels, stores and office buildings. In Ellinwood, the basement rooms and tunnels originally spanned a distance of two blocks along both sides of main street. The underground became a thriving series of connecting rooms for a host of business' as a barber shop, saloons, bathhouse, laundry, harness/leather shop, drummer rooms, sample rooms, blacksmiths and brothels. During prohibition the series of rooms and tunnels allowed for easy passage to card rooms and "lemonade" stands. With eight entrance/exit points prohibition did not exist under ground! Situated on the Santa Fe trail and later as a rail stop for the Atchison, Topeka & Santa Fe, Ellinwood became a thriving community in the 1870's and 80's.



Model A's recreate a typical 1930's street scene in Ellinwood,



Skip forward to Saturday, September 9, 2023, we had 13 Model A's, 2 modern cars and 28 Model A enthusiasts, road trip to Ellinwood for the opportunity to explore the past. We started our group tour at the Wolf Hotel with an introduction by our tour guide "Rick". Rick provided our group with an overview of Ellinwood in the early days and took us into the tunnels located on the west side of the street.



Our tour guide Rick explaining bathhouse use and laundry. You could save a dime if you did not mind using "used water" and a "used towel."



The tunnels provided an intricate maze of rooms and connecting paths below the main street of Ellinwood. Well constructed with limestone and brick, the tunnels have withstood the test of time



Rick explaining horse fly sweaters



Cooling tables were wooden platforms on which a dead body was placed, blood drained as body prepared for a funeral. Ice was placed beneath the table to keep body chilled and slowing decomposition process.

Leaving the harness shop, Rick took our group to Jung's underground Barber Shop. Wm. Jung came to Ellinwood from La Crosse, Wisconsin in 1884. Through the years Mr. Jung opened his barber shop with two chairs, had a laundry business and started the first Ellinwood Community Band. Our group learned that the "red, white & blue" barber pole used to denote a barbershop was color coded and designed to signify a barber shop because many people at the time could not read. Additionally, barbers at that time also performed an assortment of medical procedures; e.g. tonsillectomy or tooth extraction. The color red on the barber pole was the symbol for blood, blue for the veins and white was the universal color for bandages. Mr. Jung kept a couple of wheel chairs in his barber shop that were used for patients when a medical procedure was performed.



Pictures at left show vintage barber chair where patrons could get a shave, haircut and tonsillectomy if needed. To keep the business flowing smoothly the customer would be moved from the barber chair to the wheelchair when necessary.

Our underground tour Part II comprised a tour of The Wolf Hotel & Underground Storefronts. Linda was our group's guide for the 2nd part of the Ellinwood Tunnel Tour. Linda provided a brief history of the Wolf Hotel. Constructed in 1894 by John Wolf, the Italianate-style building cost about \$10,000 and was an addition to the Delmonico Hotel which stood north of the present day Wolf Hotel. The addition included 15 rooms, a new lobby and underground stores as well as the Bank of Ellinwood. The downstairs was part of the underground tunnel system and housed the Drummers' Room and Joe's Snack Counter. The Drummers' room was so named because goods were shipped in drums and the drums were brought into the Drummers' Room by salesmen for display and sale. Through the years the underground rooms function changed to a library, gym, a bar and card rooms. The Hotel has been refurbished and is still in use today and is listed on the National Register of Historic Places.



Wichita A members get ready for our lunch in the Sunflower room.

Wichita A members gathered in the Wolf Hotel Lobby.



Board walk beneath the Wolf Hotel provides access to the underground speakeasy



Located below the Wolf Hotel, the old speakeasy was brought back to life by the folks in Ellinwood, Kansas.

Our Saturday drive to Ellinwood concluded with a group catered lunch in the Sunflower Dining room of the Wolf Hotel and a quick tour of the refurbished Wolf Hotel rooms above the former bank and dining hall. The Ellinwood community has made a concerted effort to preserve and present their historical past. I cannot count the times that I have driven through Ellinwood without any thought given to the towns origins or experiences. I am once again thankful to an old Model A car that provided the opportunity to experience the historical past.

Written by Tour Leader, **Mike James**

A big Thank you to **Kathy and Mike James** for taking the group on a great tour to Ellinwood, KS. A few extra pictures!



Appreciation Dinner/Annual Meeting

The Annual meeting and Appreciation Dinner will be held on September 25th at 6:30 PM. We will have election of new officers. Meat and 2 sides (green beans and baked beans) will be provided by the club. Each member is asked to provide a side or dessert to complete the meal. **Linda Kibbe** has graciously agreed to present the program "Highlights of the Club in the past year". See everyone there!



Future Tours

All Ford's Day



Mark your calendars! October 8, 2023 is All Ford Day. **Jim Clark** will be organizing this event! Stay tuned!!

Men's Tour

2023 MEN'S TOUR – FRIDAY, OCT. 27 AND SATURDAY, OCT. 28

The tour this year will be to the Great Bend KS area, hosted by member **Steve White**, including an air show, steam cars, steam engines, car collections, good food and maybe some rusty stuff. Meet at McDonald's restaurant at 53rd Street North and Meridian in Wichita on Friday morning, October 27, and be ready to leave at 8:00 am sharp. Total driving should be around 300 miles.

Overnight stay will be in Great Bend and the tour will wrap up with lunch in Stafford KS on Saturday. We will stay at the Baltzell Lodge, 705 E. Tenth St., Great Bend. Call 620-792-4395 and mention Wichita A's. Rates are \$55.06 single, \$66.53 double, taxes included. **Make reservations early** (hunting season will be here soon).

Sign up at the September or October club meetings, or mail to **Tom Ruggles**, 5702 N. Legion, Wichita 67204. Fee is \$15 per member, \$45 for non-member. This tour is for men only. Sign up deadline is the October 23rd meeting. Friday lunch and supper and Saturday lunch are included. Questions? Call **Steve White**, 620-617-0506. Need to hitch a ride? Call Tom at 316-258-3234.



There will be **NO** Coffee and donuts in **October** due to travel schedules!

Tom Ruggles

WICHITA A'S - 2024

*****Use this form for RENEWAL -- IF NO Changes to INFO

Date Paid _____

NAME _____

_____ RENEWAL (Dues are \$25) _____ AD (Business Card \$25)

CIRCLE how you want your newsletter? (E-mail, Mailed, or Both)

IF changes to Address, Phone or E-mail please use longer form.

MAKE CHECKS PAYABLE TO: WICHITA A's

*****Use this form If You have Changes to INFO OR FOR A NEW MEMBER

WICHITA A'S MODEL A FORD CLUB – 2024

(Oct.1 thru Sept. 30)

ALL CLUB DUES (Oct.1 thru Sept. 30) are \$25. _____ NEW or _____ RENEWAL

PLEASE CHECK HOW YOU WOULD LIKE TO RECEIVE YOUR NEWSLETTER:

_____ ONLY E-MAILED

_____ ONLY MAILED HARD COPY

_____ BOTH E-MAILED & MAILED HARD COPY

Commercial Newsletter Ad (Enclose Business Card IF New or Updated) _____ \$25/ Year

NAME _____ BIRTHDAY (MO/ DAY) _____

SPOUSE'S NAME _____ BIRTHDAY (MO/ DAY) _____

ADDRESS _____

CITY _____ STATE _____ ZIP _____

HOME PHONE (IF want printed in roster) _____

MEMBER CELL (IF want printed in roster) _____

SPOUSE CELL (IF want printed in roster) _____

E-MAIL ADDRESS _____

Include me on the Club e-mail list? YES or NO

Model A Year & Body Style: _____

MAKE CHECKS PAYABLE TO: WICHITA A's

BRING TO THE CLUB MEETING OR MAIL TO: WICHITA A'S

P.O. BOX 25

MAFFI Newsletter Minute

September MAFFI Minute

MAFFI Model A Days, September 15-16, 2023: The planning is complete for this years' Model A Days. The theme for this year is "*Open Cars*". There will be a special gate access to Model A parking. A two-day swap meet is planned. You will be able to "*Ride-the-A*" around the Gilmore campus in a Model A car, AA stake bed truck and/or maybe even a Model A school bus. There will be a Model A driving school for those who have registered for this activity. A catered dinner with a tour of the Kellogg Bird Sanctuary as well as a tour of the Kellogg Manor House is planned, (these require registration). Seminars will include a fashion seminar; a technical seminar-The ABC's of the Model A Engine; a touring seminar-Road-Trip 101; and a special guest speaking on the Great Race. There will again be a MAFFI sales table. (It is requested shirts be pre-ordered to be sure your shirt in your size is available.) The Henry Ford Heritage Association will be in attendance. A Jazz Band will perform. Some special rate rooms may still be available, although they are filling up. All of this is happening at Hickory Corners, Michigan. For more information and registration procedures, visit the MAFFI web page. ***Come visit, what a way for Model A folks to end the summer season for 2023!***

Happy motoring,
Mike DuBreuil
MAFFI Board of Trustees
Secretary

Thank you,
Charles M (Mike) DuBreuil, MAFFI Trustee
clubcontact@maffi.org

National Model A Clubs

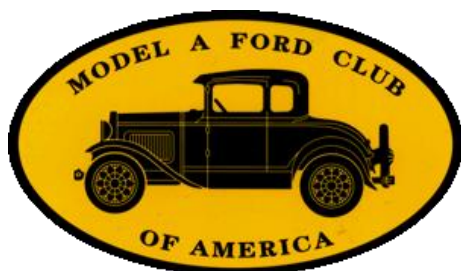

The Wichita A's Model A Ford Club encourages members to join both National MARC and MAFCA Clubs.



MAFCA

250 S. Cypress St.
La Habra, CA 90631-5515
www.mafca.com
U.S. Membership Cost: \$50

For membership information you can check MAFCA and MARC web sites.

MARC

6721 Merriman
Garden City, MI 48315
<http://modelarestorers.org>
U.S. Membership Cost: \$45

TECH ARTICLE

BUMPER SEAT

Even though a Model A comes with two running boards, have you ever noticed Model A'ers always seem to plop down on the front bumper when they are "kicking tires or telling fish stories?" And as I'm sure you've found out, that 1/4" piece of steel isn't the most comfortable sofa made - I always end up with a case of terminal bumper rash.

If you are tired of getting Model A bumper rash, try building a Model A bumper seat. Cut a 10" circle out of 3/4" plywood. Sand and ease (roll to a smooth, rounded edge) the top edges. Attach two 1" x 2" x 8" pine strips on the underside with 2" screws. Space the strips 1/4" apart.

While you're at it, make a pair so your traveling companion or fellow "fish story teller" has a place to sit too.

You now have a comfortable seat that quickly slips down over

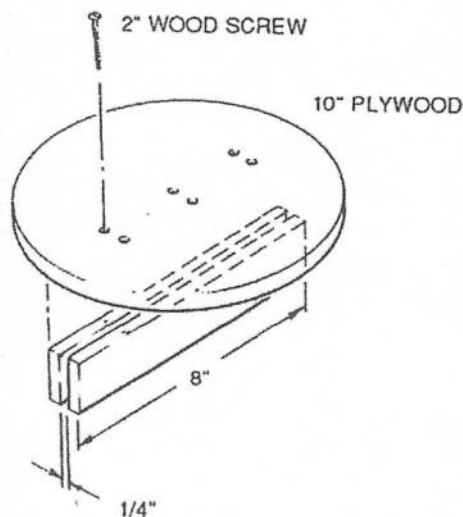

the front bumper and is just as easily removed and thrown under the seat (or in the trunk) when you're ready to drive away.

Submitted by Gary Lloyd, Dallas Model A Ford Club

ERA Fashion

A



Topcoats were very important and the well-dressed man had at least one.

- A. New topcoat for the 1930 spring season. Covert cloth topcoat with pointed, notched lapels and pointed collar. Note the placket with hidden buttons.
- B. Tweed overcoat, with notched, rounded lapels and collar. The shirt has a round point collar.
- C. The "Metropole Conservative" three-button, double breasted overcoat. Peaked lapels, medium wide collar, and straight hanging back.

B



C



LOCAL AND NATIONAL CALENDARS

2023 SWAP MEET & CAR SHOW SCHEDULE

October 1, 2023	All Ford's Day SHOW-N-SHINE	Wichita KS
October 3-6, 2023	Hershey Region AACA Swap Meet	Hershey, PA
March 15-16, 2024	Chickasha Pre-War Swap Meet 2024	Chickasha, OK
April 25-27, 2024	Pate Swap Meet, Texas Motor Speedway www.pateswapmeet.com	Fort Worth, TX



2023 –2024 FUTURE REGIONAL & NATIONAL MODEL A MEETS

Nov 30-Dec 2, 2023.....	MAFCA National Awards Banquet.....Santa Maria, CA
April 4-6, 2024.....	MARC 2024 National Membership Meet.....Joliet, Illinois
May 21-23, 2024.....	MARC 2024 National Tour.....Berlin, Ohio
June 23-20, 2024.....	MAFCA National Convention hosted by Santa Maria A's.....Ruidoso, New Mexico



ERIC WENINGER
OWNER

2045 S BEDFORD ST
WICHITA, KS 67207

316-619-1821 CELL
316-685-2553 SHOP

info@modelamedic.com
www.modelamedic.com
www.facebook.com/modelamedic

**THE
MODEL A
MEDIC LLC**



NEW AND USED MODEL A FORD PARTS

SPECIALIZING IN FULL SERVICE REPAIRS
AND RESTORATION

B&B Electric Motor Co.
Your One Stop Industrial Service Center

New • Repair • Rewind

Electric Motors • Pumps

Phone (316) 267-1238 • 1-800 499-1238
Fax (316) 267-0599 • Emergency (316) 641-0806
email: bbemc@msn.com • bbelectricmotor.com

332 Lulu
Wichita, KS 67211

Ed Giesen
Customer Service

Join the Wichita A's.
We meet on the 4th Monday of each
month except December

Minisa Park, 704 W. 13th Wichita,
KS at 7 PM

Mishelle Whitney

mishelle@loracompany.com

624 E. Harry Street

316-263-2565 * 1-800-554-0144

Wichita, KS 67211

Fax 316-263-5181

www.loracompany.com

Lorac Company, Inc.

Basement Window Well Cover * Powder Coating

* Custom Metal Fab * Media Blasting



COSH
REAL ESTATE SERVICES

RAY HARSHFIELD

Realtor

ADDRESS
1356 N Emporia St
Wichita, KS 67214

CELL: 316-305-1705
OFFICE: 316-260-2674
FAX: 316-260-9902
ray.harshfield@cosh.us

Go To:

[Wichita A's Model A Ford Club
\(wichitaas.com\)](http://wichitaas.com)

To download forms to join the Wichita
A's Model A Ford Club, MAFCA,
MARC or MAFFI .



**Top Notch
Heating & Cooling**

Jesse James
Service/Install Manager
(316) 253-0819

24 Hour Emergency Service

ELLERMAN SPEEDOMETERS

STEWART-WARNER FOR
FORD MODEL A
OVAL OR ROUND
RESTORATION



DENNIS ELLERMAN
316.722.2107 OR
316.765.1506

\$150 PPD + CORE 2-YEAR GUARANTEE

Wichita A's Model A Ford Club
P.O. Box 25
Wichita, KS 67201



Address Service Requested

Wichita A's Model A Ford Club Contacts

If you chose to email one of the following contacts, go to our web page at www.wichitaas.com and click on contacts and send your email from there. Include the person you want to email in your message

- President**, James Sharp
..... (316) 644-1062
- Vice President**, Frank Chenoweth
..... (316) 250-7026
- Secretary**, Kathy James
..... (316) 734-2884
- Treasurer**, Claudia Ellerman
..... (316) 640-4197
- Tour Chairman**, Don Grabendike
..... (316) 838-1765
- Membership**, Linda Kibbe
..... (316) 789-5348
- Newsletter Editor**, Sheila Orr
sheorr@sbcglobal.net..... (316) 207-8878
- Webmaster**, Darren Schuster

The Rumbleseat Review is the official publication of the Wichita A's Model A Ford Club, Inc., a local chapter of the Model A Ford Club of America and the Model A Restorers Club. It's purpose is to keep members informed of past, present and future events, activities, and club news. In addition, this newsletter includes articles and other information to aid in the restoration and enjoyment of the Model A Ford automobile.

This publication is mailed or emailed to members, prospective members and editors of similar publications prior to monthly meetings. Meetings are usually the fourth Monday of the month. Members may publish antique car related ads only for free of charge which includes items wanted, items for sale, or items for trade. We invite members to submit articles containing technical Model A information and other interesting tidbits for publication in this newsletter. Items to be published must be submitted to the newsletter editor by deadline shown in the calendar. Wichita A's membership dues are \$25.00, per year (October to September30). MAFCA dues are \$50.00 per year and MARC dues are \$45.00 per year. A business card advertisement in this newsletter is \$25.00 per year.